

Parallel 3-Finger Gripper

# HP05 Series



- ◆ 3-Finger parallel gripper with the use of the cross roller guide
- ◆ High repeat accuracy:  $\pm 0.01$  mm
- ◆ 2 lever shapes  
Short type and long type.

# HP05 Series

## Model Code No.

**HP05 - 16 - S ※ ZE135 A 2**

Series Name

**Bore Size**  
16:16mm  
20:20mm

**Lever shape**  
L: Long type  
S: Short type

**Number of Switches**  
1:1 Switch  
2:2 Switches

**Switch Lead Wire Length**  
A:1m  
B:3m

●Switch Type No Code: No Switch

<b>ZE135</b>	<b>ES13</b>
2 Wire System Solid State Switch, Straight Type	

<b>ZE235</b>	<b>ES23</b>
2 Wire System Solid State Switch, L-shaped	

<b>ZE155</b>	<b>ES(P)15</b>
3 Wire System Solid State Switch, Straight Type	

<b>ZE255</b>	<b>ES(P)25</b>
3 Wire System Solid State Switch, L-shaped	



●Switch details→P.521~528

## Internal Structure Diagram

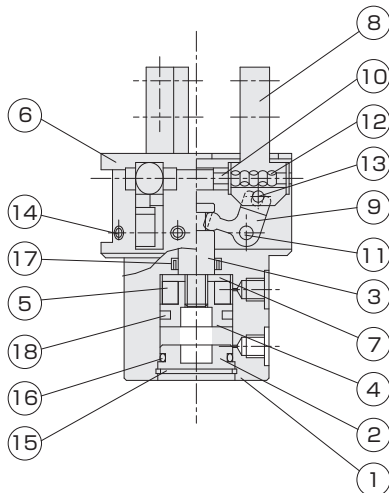

## Parts List

NO	Name	Material
1	Main Body	Aluminum Alloy
2	Head Cover	Aluminum Alloy
3	Piston Rod	Stainless Steel
4	Piston	Aluminum Alloy
5	Magnet	Resin
6	Pressure Cover	Carbon Steel
7	Pressure Cover	Aluminum Alloy
8	Lever	Carbon Tool Steel
9	Action Lever	Carbon Steel
10	Rail	Carbon Tool Steel
11	Fulcrum Pin	Carbon Tool Steel
12	Roller	High Carbon-chromium Bearing Steel
13	Roller	High Carbon-chromium Bearing Steel
14	Hexagon Socket Head Setscrew	Carbon Steel
15	Hole Locating Snap Ring	Hard Steel
16	O Ring	NBR
17	Rod Packing	NBR
18	Piston Packing	NBR

## Specifications

Fluid	Air
Maximum Operating Pressure [MPa]	0.7
Proof Pressure [MPa]	1.05
Operating Temperature [°C]	0~60 (No Freezing)
Lubrication	Not Required (Required for sliding parts of the machine)
Pipe Bore	M5×0.8
Maximum Operating Cycle [Cycle/min]	180
Applicable Switch	ZE, ES Type (Solid State Switch)

Action Type	Model	Bore Size [mm]	Minimum Operating Pressure [MPa]	Opening/ Closing Stroke [mm]	Gripping Force [N] <sup>Note)1</sup>		Outside Dimensions (D x L) [mm] <sup>Note)2</sup>	Product Mass [g]
					Close	Open		
Double Acting	HP05-16-S	16	0.2	8	20	27	42×50	156
	HP05-16-L	16	0.2	8	20	27	42×50	168
	HP05-20-S	20	0.15	12	27	36	54×58.5	284
	HP05-20-L	20	0.15	12	27	36	54×58.5	308

Note 1) The grip force is an effective value when the grip point L is 30 mm and the pressure is 0.5 MPa.

Note 2) The outside dimensions indicate the main body dimensions. (Excluding the lever)

## Effective Gripping Force (Closing Force)

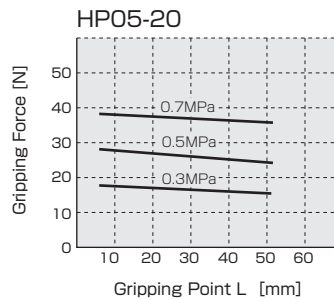
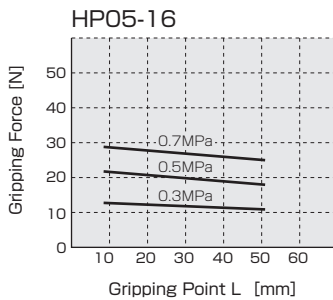

## Gripping Point Limit Range

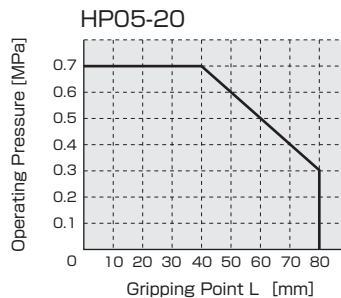
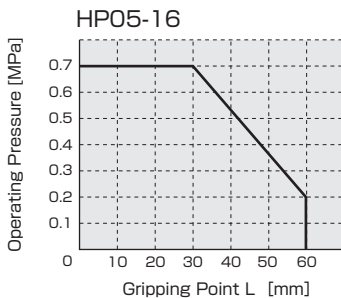

**Dimensions HP05-16-S**

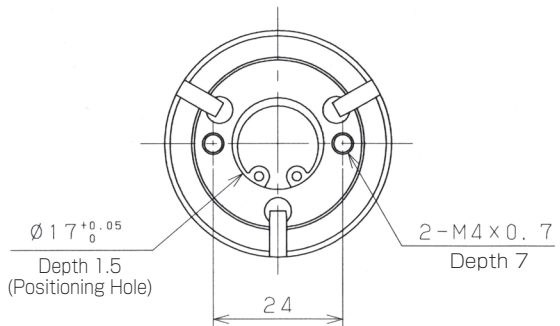
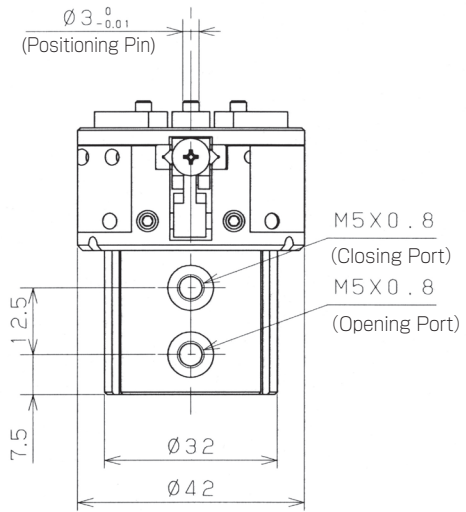
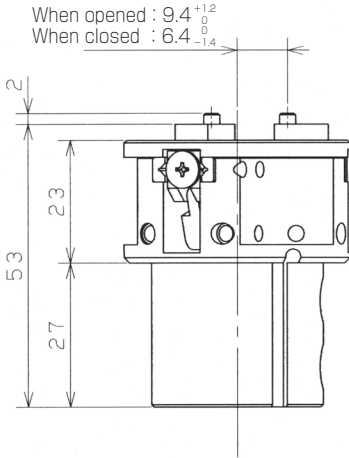
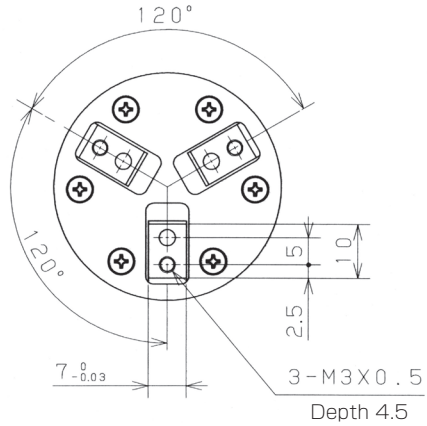

**Dimensions HP05-16-L**

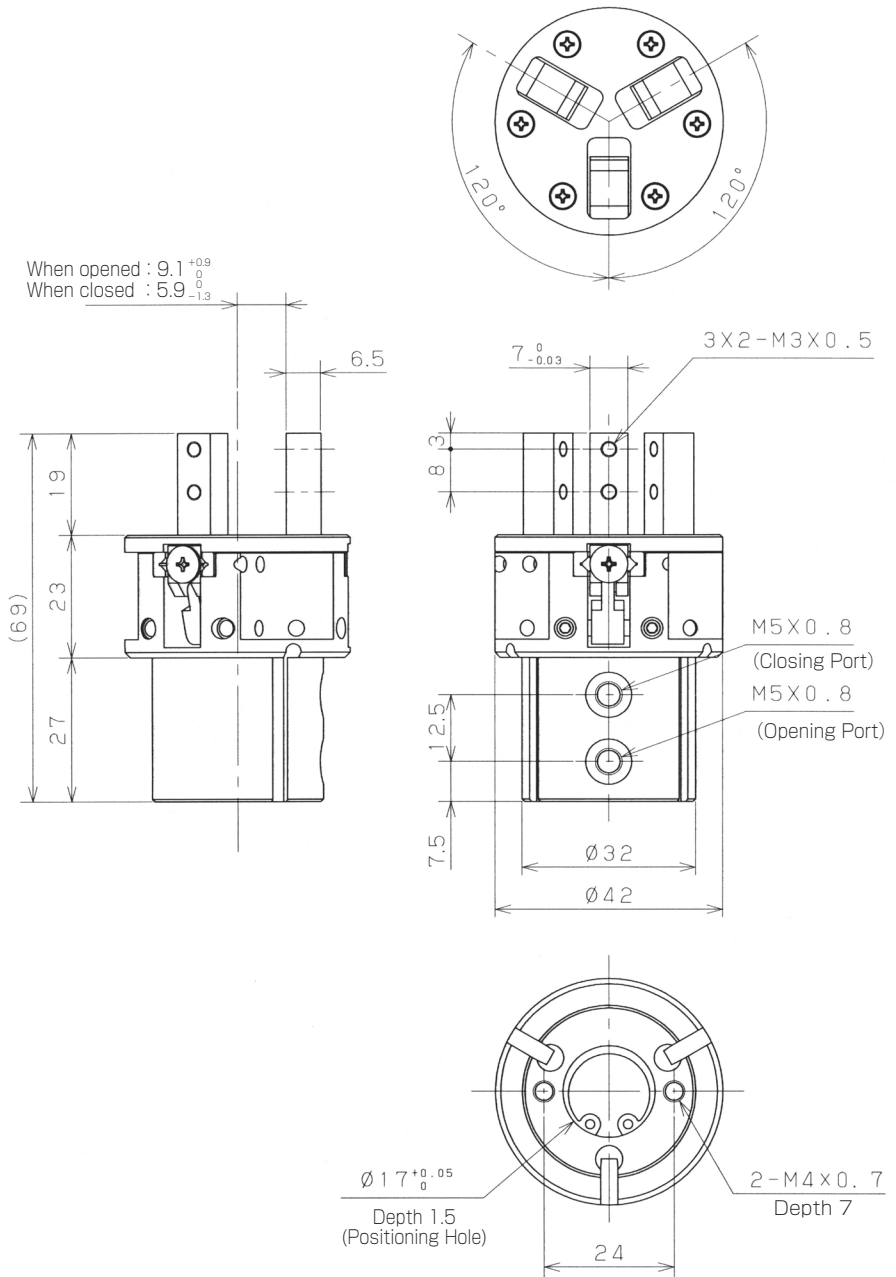

**Dimensions HP05-20-S**

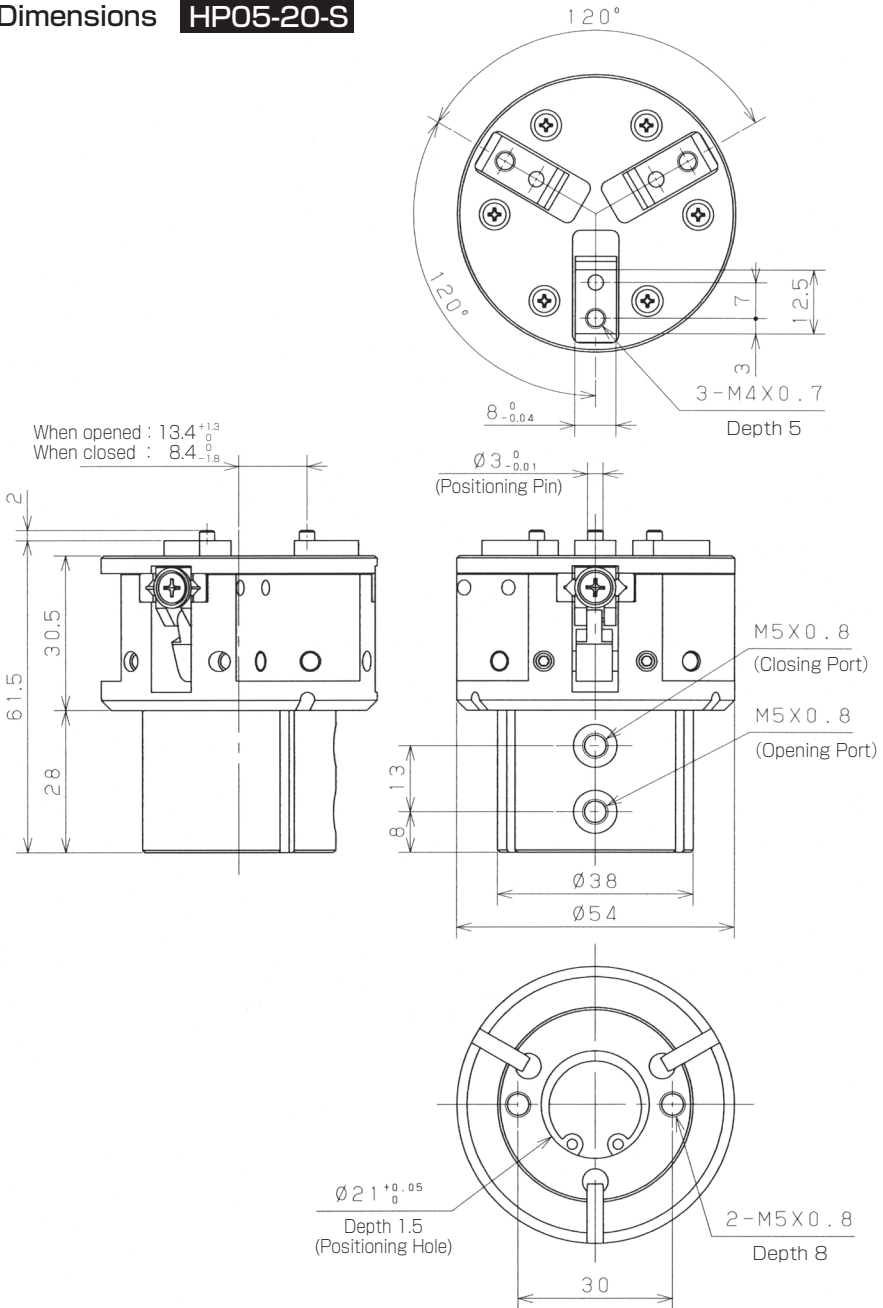

**Dimensions HP05-20-L**

